

WA 33 B

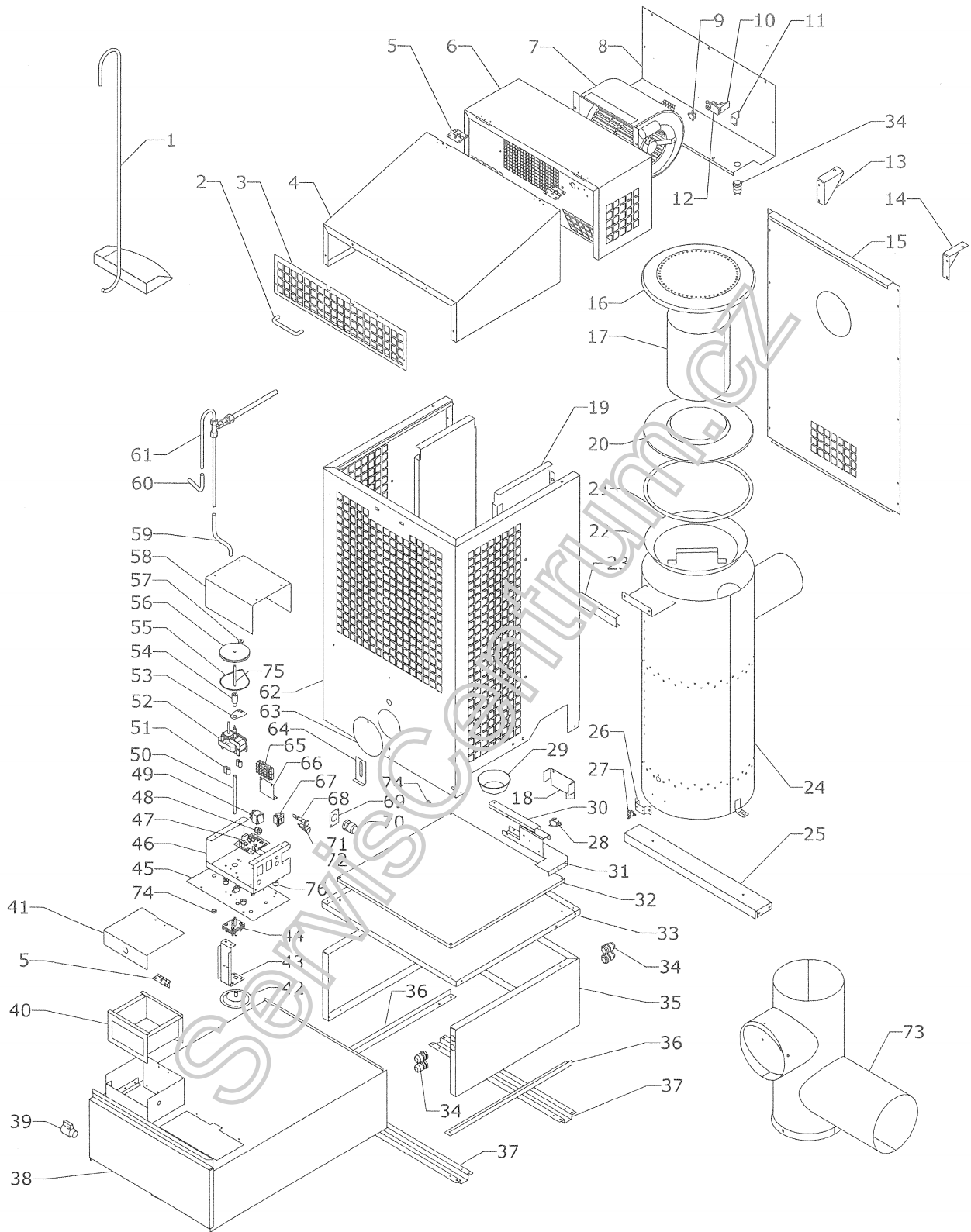

PARTS LIST

NR	CODE	NAME	NR	CODE	NAME
1	4517.229	SHOVEL	39	4517.246	BALL VALVE FERRO MINI 1/2"-1/2"
2	4517.230	COVER HANDLE	40	4517.208	INLET FILTER
3	4517.161	SHIELD GRID	41	4517.185	INLET COVER
4	4517.160	TOP COVER	42	4517.268	FUEL FILTER
5	4517.231	HINGE 50x40	43	4517.232	PUMP HANDLE
6	4517.249	FAN HOUSING IV	44	4517.257	FUEL PUMP
7	4517.302	FAN DDL 133-190 AC230V 50Hz	45	4517.219	STEERING PANEL BASE
8	4517.165	FAN HOUSING III	46	4517.220	STEERING PANEL COVER
9	4510.436	THERMAL CUT-OUT WITH RESET F 90	47	4517.404	PUMP MOTOR CONTROL BOX
10	4510.612	RESET LEVER	48	4510.605	STRAIN RELIEF BUSHING SR-6P1
11	4517.274	LEVER STOP	49	4513.409	SWITCH 1K 16A 250V LED GREEN
12	4510.611	RESET LEVER BASE	50	4517.233	DRIVING PIPE L=130mm
13	4517.168	HOUSING SUPPORT II	51	4510.613	DISTANCE BUSH
14	4517.167	HOUSING SUPPORT I	52	4517.303	PUMP MOTOR
15	4517.174	HOUSING SHIELD III	53	4517.271	BUSH SUPPORT
16	4517.200	CHAMBER COVER	54	4517.270	DRIVING WHEEL BUSH
17	4517.202	CHAMBER PIPE III	55	4517.612	DRIVING BELT WA
18	4517.162	MICROSWITCH HOUSING	56	4517.609	DRIVING WHEEL 80
19	4517.172	HOUSING SHIELD I	57	4517.610	DRIVING WHEEL 10
20	4517.199	CHAMBER DISK	58	4517.221	STEERING PANEL COVER II
21	4517.198	CHAMBER RING	59	4517.607	CONNECTION PIPE
22	4517.205	COMBUSTION DISH	60	4517.606	OVERFLOW PIPE
23	4517.171	HOUSING SUPPORT	61	4517.243	FUEL SUPPLY SET
24	4517.196	COMBUSTION CHAMBER - BODY	62	4517.175	MAIN HOUSING
25	4517.170	CHAMBER SUPPORT	63	4517.193	SHIELD COVER
26	4517.258	THERMOSTAT HANDLE	64	4517.169	HOUSING HANDLE
27	4510.404	OVERHEAT SENSOR 16A/250V NO T60	65	4517.408	CONNECTION SLAT SOCKET+PLUG 12T 4^2
28	4517.403	MICROSWITCH NC 16A 250V	66	4517.209	JOINING SLAT SUPPORT
29	4517.191	OVERFLOW BOWL	67	4517.401	SWITCH 3P BLACK/WHITE
30	4517.190	OVERFLOW SUPPORT	68	4514.415	INDICATOR LIGHT 230V IP44 D9,5
31	4517.192	OVERFLOW SUPPORT II	69	4517.273	CHANNEL PLATE
32	4517.176	BOTTOM SHIELD I	70	4517.407	CABLE GLAND PG-16 BLACK
33	4517.177	BOTTOM SHIELD II	71	4514.400	FUSEHOLDER 5x20, 6,3A
34	4517.406	CABLE GLAND PG-11 BLACK	72	4517.405	FUSE 5X20 ZKS 1A
35	4517.189	BOTTOM SHIELD	73	4517.242	AIR CONTROLLER
36	4517.188	BOTTOM SUPPORT II	74	4511.621	SEAL WIRE 14.2x8x11x1.6x4.8
37	4517.187	BOTTOM SUPPORT I	75	4517.272	WHEEL SHAFT 80
38	4517.180	FUEL TANK - BODY	76	4510.628	DISTANCE BUSH 6,3x15x10